

特征 Features

- 齐纳击穿阻抗低; Low Zener Impedance
- 最大功率耗散 150mW; Power Dissipation of 150mW
- 高稳定性和可靠性。High Stability and High Reliability

机械数据 Mechanical Data

- 封装: SOD-523 封装 SOD-523 Small Outline Plastic Package
- 极性: 色环端为负极 Polarity: Color band denotes cathode end
- 安装位置: 任意 Mounting Position: Any

极限值和温度特性(TA = 25°C 除非另有规定)

Maximum Ratings & Thermal Characteristics (Ratings at 25°C ambient temperature unless otherwise specified.)

参数 Parameters	符号 Symbol	数值 Value	单位 Unit
功率消耗 Power Dissipation	Pd	150 ¹⁾	mW
正向压降 Forward Voltage @IF=10mA	Vf	0.9 ²⁾	V
存储温度 Storage temperature range	Ts	-55-+150	°C

1) Device mounted on ceramic PCB: 7.6mm x 9.4mm x 0.87mm with pad areas 25mm²

2) Short duration test pulse used to minimize self-heating effect

3) f=1KHz

电特性 (TA = 25°C 除非另有规定)

Electrical Characteristics (Ratings at 25°C ambient temperature unless otherwise specified).

Device	Marking	Zener Voltage Range				Maximum Zener Impedance ³⁾			Maximum Reverse Current		Typical Temperature coefficient @ IZTC=mV/°C		Test Current IZTC
		Vz@Izt			Izt	Zzt @Izt	Zzk @Izk	Izk	IR	VR	Min	Max	
		Nom(V)	Min(V)	Max(V)									
BZX584C2V0	Z10	2.0	1.85	2.15	5	150	600	1.0	100	1.0	-3.5	0	5
BZX584C2V4	Z11	2.4	2.2	2.6	5	100	600	1.0	50	1.0	-3.5	0	5
BZX584C2V7	Z12	2.7	2.5	2.9	5	100	600	1.0	20	1.0	-3.5	0	5
BZX584C3V0	Z13	3.0	2.8	3.2	5	95	600	1.0	10	1.0	-3.5	0	5
BZX584C3V3	Z14	3.3	3.1	3.5	5	95	600	1.0	5	1.0	-3.5	0	5
BZX584C3V6	Z15	3.6	3.4	3.8	5	90	600	1.0	5	1.0	-3.5	0	5
BZX584C3V9	Z16	3.9	3.7	4.1	5	90	600	1.0	3	1.0	-3.5	0	5
BZX584C4V3	Z17	4.3	4.0	4.6	5	90	600	1.0	3	1.0	-3.5	0	5
BZX584C4V7	Z1	4.7	4.4	5.0	5	80	500	1.0	3	2.0	-3.5	0.2	5
BZX584C5V1	Z2	5.1	4.8	5.4	5	60	480	1.0	2	2.0	-2.7	1.2	5
BZX584C5V6	Z3	5.6	5.2	6.0	5	40	400	1.0	1	2.0	-2.0	2.5	5
BZX584C6V2	Z4	6.2	5.8	6.6	5	10	150	1.0	3	4.0	0.4	3.7	5
BZX584C6V8	Z5	6.8	6.4	7.2	5	15	80	1.0	2	4.0	1.2	4.5	5
BZX584C7V5	Z6	7.5	7.0	7.9	5	15	80	1.0	1	5.0	2.5	5.3	5
BZX584C8V2	Z7	8.2	7.7	8.7	5	15	80	1.0	0.7	5.0	3.2	6.2	5
BZX584C9V1	Z8	9.1	8.5	9.6	5	15	100	1.0	0.5	6.0	3.8	7.0	5
BZX584C10	Z9	10	9.4	10.6	5	20	150	1.0	0.2	7.0	4.5	8.0	5
BZX584C11	Y1	11	10.4	11.6	5	20	150	1.0	0.1	8.0	5.4	9.0	5
BZX584C12	Y2	12	11.4	12.7	5	25	150	1.0	0.1	8.0	6.0	10.0	5
BZX584C13	Y3	13	12.4	14.1	5	30	170	1.0	0.1	8.0	7.0	11.0	5



BZX584Cxx Series

Device	Marking	Zener Voltage Range				Maximum Zener Impedance			Maximum Reverse Current		Typical Temperature coefficient @ IZTC=mV/°C		Test Current IZTC
		Vz@Izt			Izt	Zzt @Izt	Zzk @Izk	Izk	IR	VR	Min	Max	
		Nom(V)	Min(V)	Max(V)									
BZX584C15	Y4	15	13.8	15.6	5	30	200	1.0	0.1	10.5	9.2	13.0	5
BZX584C16	Y5	16	15.3	17.1	5	40	200	1.0	0.1	11.2	10.4	14.0	5
BZX584C18	Y6	18	16.8	19.1	5	45	225	1.0	0.1	12.6	12.4	16.0	5
BZX584C20	Y7	20	18.8	21.2	5	55	225	1.0	0.1	14.0	14.4	18.0	5
BZX584C22	Y8	22	20.8	23.3	5	55	250	1.0	0.1	15.4	16.4	20.0	5
BZX584C24	Y9	24	22.8	25.6	5	70	250	1.0	0.1	16.8	18.4	22.0	5
BZX584C27	Y10	27	25.1	28.9	2	80	300	0.5	0.1	18.9	21.4	25.3	2
BZX584C30	Y11	30	28.0	32.0	2	80	300	0.5	0.1	21.0	24.4	29.4	2
BZX584C33	Y12	33	31.0	35.0	2	80	325	0.5	0.1	23.1	27.4	33.4	2
BZX584C36	Y13	36	34.0	38.0	2	90	350	0.5	0.1	25.2	30.4	37.4	2
BZX584C39	Y14	39	37.0	41.0	2	130	350	0.5	0.1	27.3	33.4	41.2	2
BZX584C43	Y15	43	40.0	46.0	2	100	700	1.0	0.1	32.0	10.0	12.0	5

Typical characteristics

Zener Characteristics (Vz Up to 10 V)

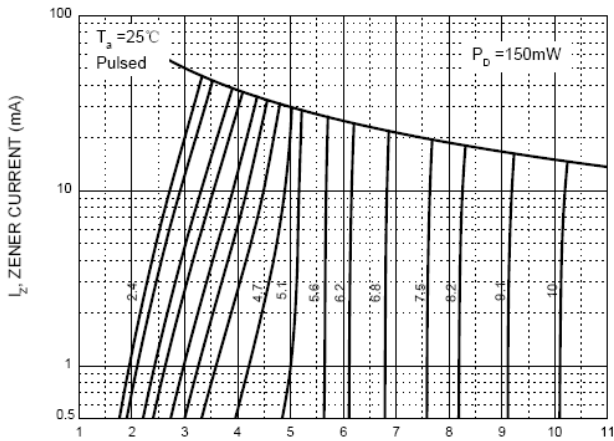

Zener Characteristics (11 V to 43 V)

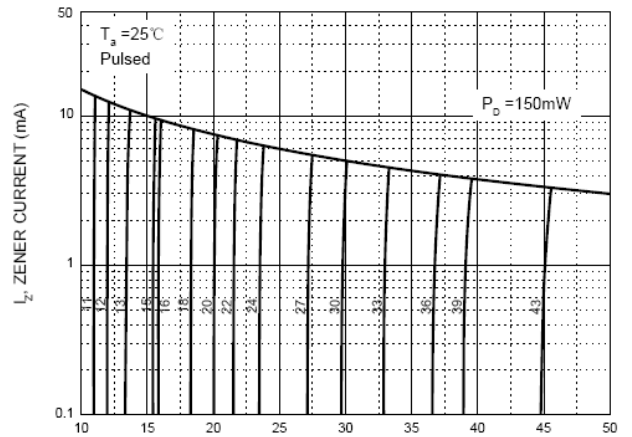

Temperature Coefficients

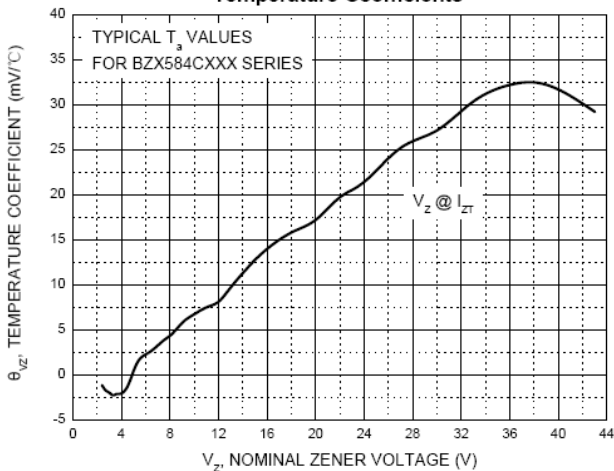

Typical Leakage Current

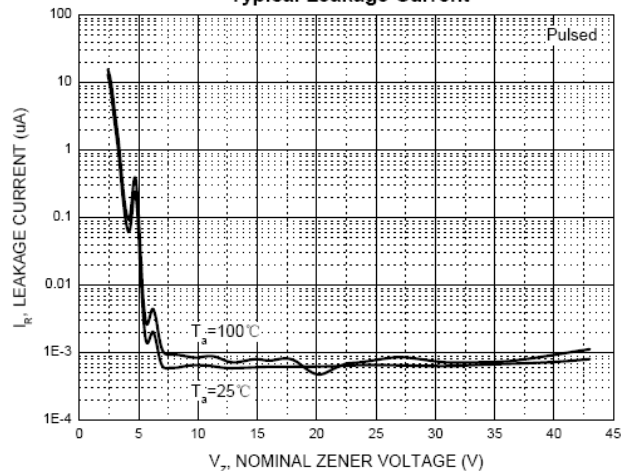

BZX584Cxx Series

Typical Capacitance

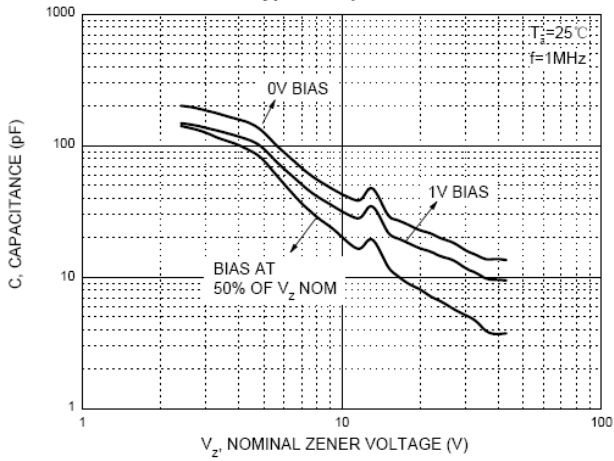

Effect of Zener Voltage on Zener Impedance

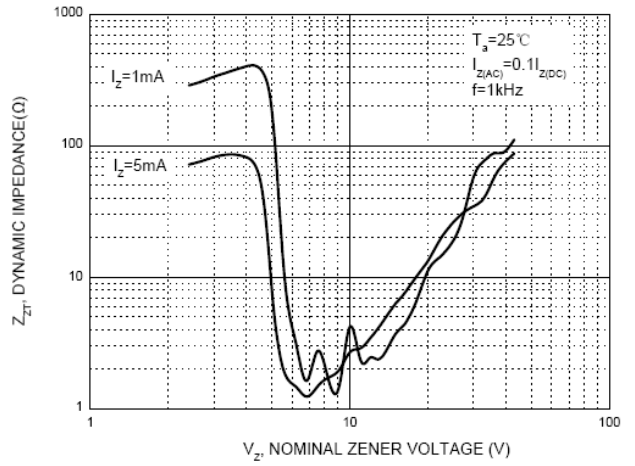

Power Derating Curve

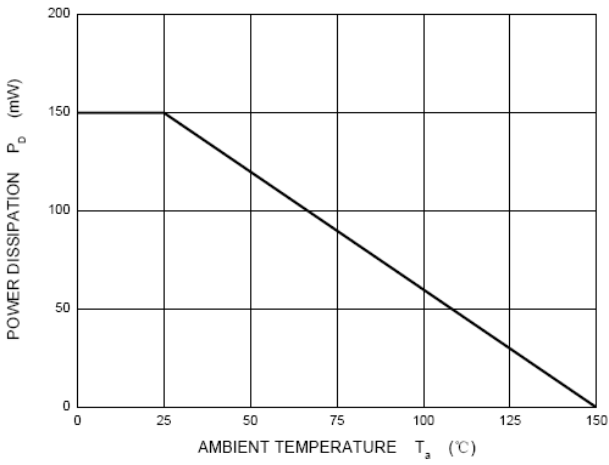

SOD-523 PACKAGE OUTLINE

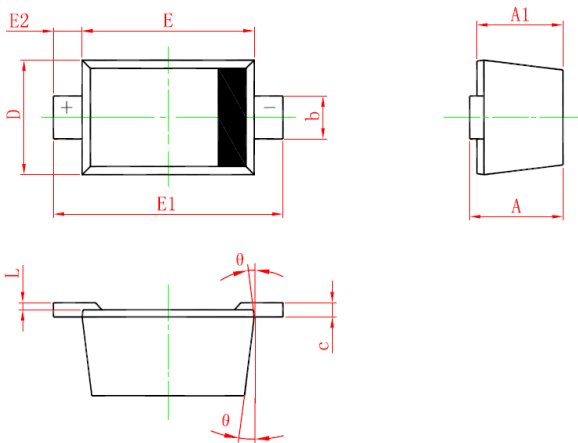

Symbol	Dimensions In Millimeters		Dimensions In Inches	
	Min	Max	Min	Max
A	0.510	0.770	0.020	0.031
A1	0.500	0.700	0.020	0.028
b	0.250	0.380	0.010	0.015
c	0.080	0.150	0.003	0.006
D	0.750	0.850	0.030	0.033
E	1.100	1.300	0.043	0.051
E1	1.500	1.700	0.059	0.067
E2	0.200 REF		0.008 REF	
L	0.010	0.070	0.001	0.003
θ	7° REF		7° REF	

SOD-523 Suggested Pad Layout

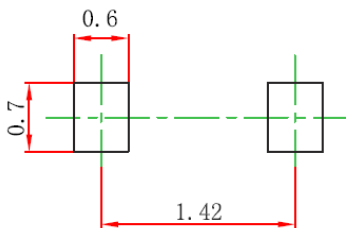

- Note:
1. Controlling dimension: in millimeters.
 2. General tolerance: ±0.05mm.
 3. The pad layout is for reference purposes only.